

# Knobbe Martens

Knobbe Martens Webinar  
Series: Strategic  
Considerations Under Section  
103 – Strategic Claim Drafting  
and Secondary Considerations

December 18, 2020

Dan Altman

Michael Guiliana

Hironori Kubota

Mauricio. A. Uribe

# Statutory Requirements

# Statutory Requirements – Patentability of Inventions

---

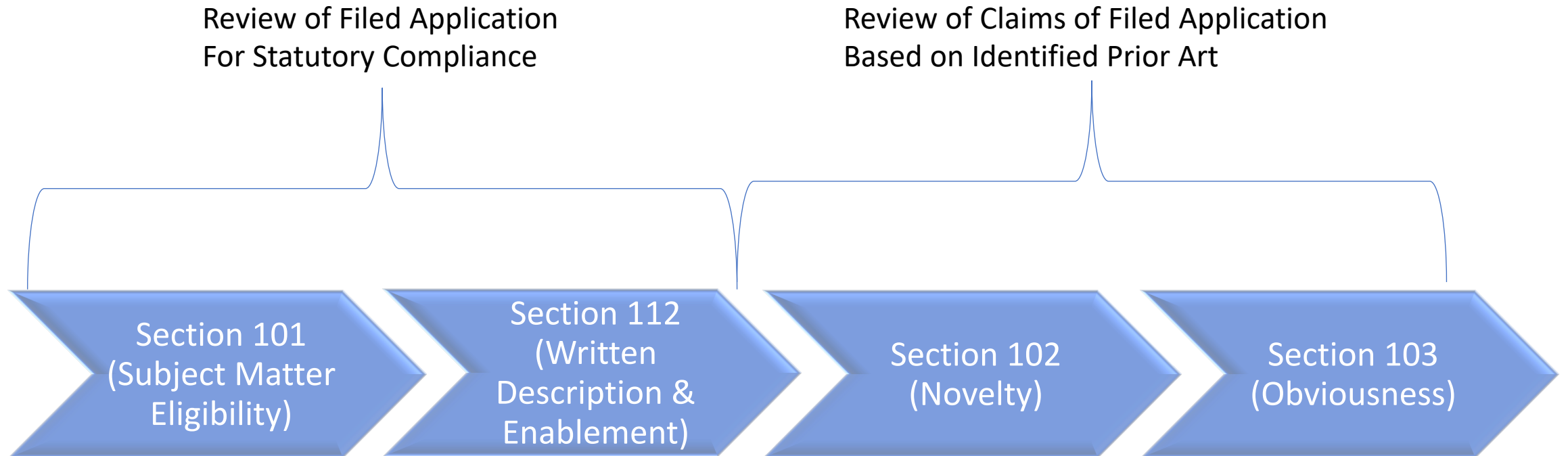

# Statutory Requirements – Patentability of Inventions

---



## 35 U.S. Code § 103

A patent for a claimed invention may not be obtained, notwithstanding that the claimed invention is not identically disclosed as set forth in section 102, if the differences between the claimed invention and the prior art are such that the claimed invention as a whole would have been obvious before the effective filing date of the claimed invention to a person having ordinary skill in the art to which the claimed invention pertains. Patentability shall not be negated by the manner in which the invention was made.

## General Prosecution Tips - Addressing Section 103 Rejections/Rationale

---

- References must teach or suggest cited concepts
- Reasons for obviousness or combination of prior art teachings
- Teaching away
- Inoperability of combined teachings
- Improper hindsight combination
- Non-analogous art

# Statutory Requirements – Patentability of Inventions

---



## 35 U.S. Code § 103

A patent for a claimed invention may not be obtained, notwithstanding that the claimed invention is not identically disclosed as set forth in section 102, if the differences between the claimed invention and the prior art are such that the claimed invention as a whole would have been obvious before the effective filing date of the claimed invention to a person having ordinary skill in the art to which the claimed invention pertains. Patentability shall not be negated by the manner in which the invention was made.

## General Prosecution Tips - Addressing Section 103 Rejections/Rationale

---

- References must teach or suggest cited concepts
- Reasons for obviousness or combination of prior art teachings
- Teaching away
- Inoperability of combined teachings
- Improper hindsight combination
- Non-analogous art

# Piecemeal Combinations

---

determine service availability for a network-based service for processing the received request;

**evaluate local authentication and authorization information based on unavailability of the network-based service**

Reference 1:

- Teaches processing locally message received from server
- Does not teach checking for availability
- Does not teach local processing if unavailable

Reference 2:

- Teaches checking for network availability
- Does not teach authentication or authorization
- Does not teach local processing if unavailable



## Part II – Overcoming *Prime Facie* Obviousness

- If *Prime Facie* Obviousness Exists, evidence of Non-Obviousness can overcome rejection

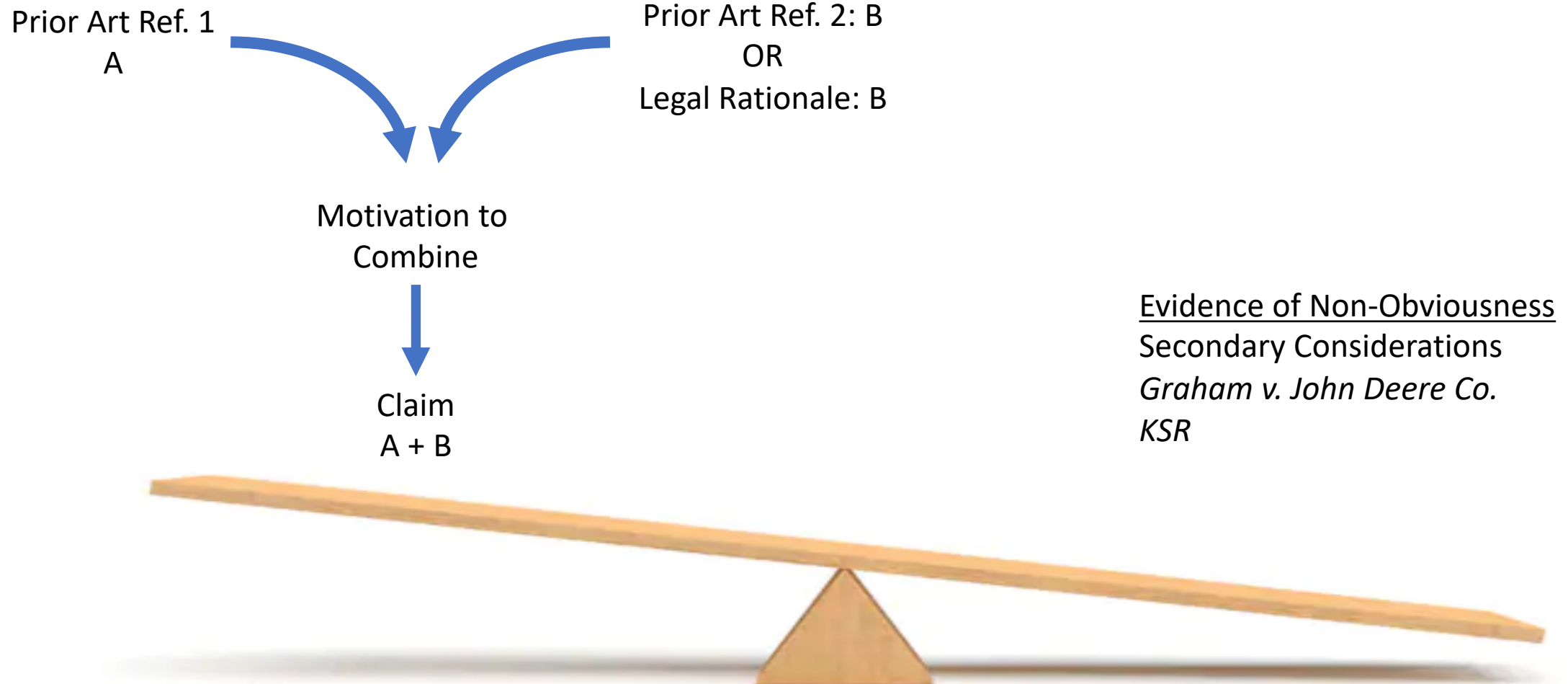

# Secondary Considerations

---

Secondary considerations are a non-exhaustive list of economic and motivational considerations that can establish overcome an obviousness rejection:

## Common Considerations

- criticality or unexpected results
- the invention's commercial success,
- long felt but unresolved needs,
- the failure of others,
- skepticism by experts,
  
- **Other Considerations**
- praise by others,
- teaching away by others,
- recognition of a problem,
- copying of the invention by competitors

# Evidence of Criticality and Unexpected Results – Often Known Before Filing

---

- Data or Opinion that shows claimed invention produces
  - Unexpectedly good results, more than mere proportional improvement of known performance parameters
    - Attorney Argument Not Enough
  - Result that is “different in kind rather than degree”
    - Results, Benefits, or Functions not in prior art
  - Examples in MPEP § 2145
- Can be included in Specification
  - Better if contained in Original Specification
  - If now, Third Party Declaration is better than inventor or applicant
  - Inventor or Applicant is allowed
- Tests/Data/Benefits/Results can be discovered and submitted after filing

# Criticality Example

- Claim: Fence Post with 2 straight and 2 counter-sunk holes within 4 inch span
  - Prior Art Reference: Fence Post piece with straight and counter-sunk holes next to each other
  - Obviousness Rejection: P.A.R. + Obvious to Duplicate Parts
  - Rejection overcome with 1 interview
    - Specification explains 2 straight and 2 countersunk holes within 4 inch span allows for use of preferred fastener.

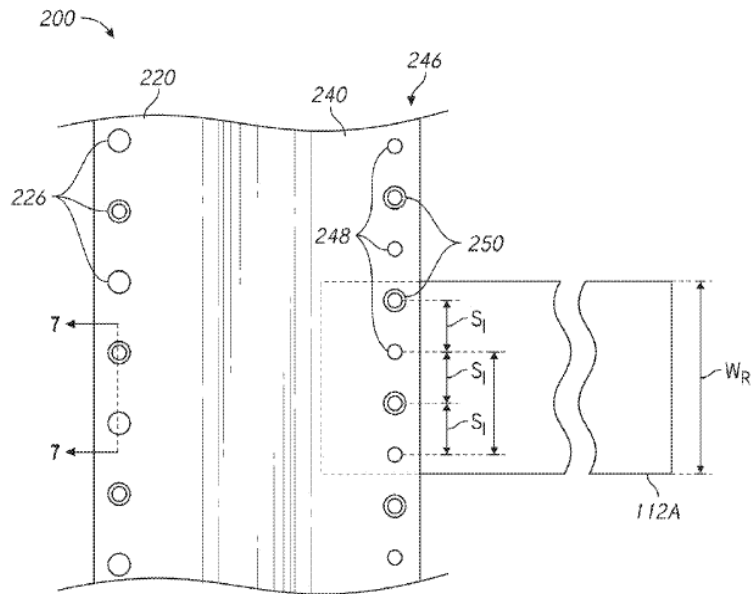
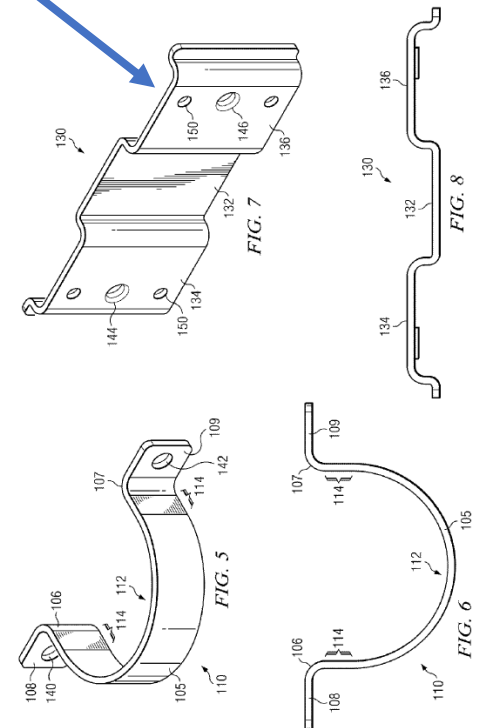

FIG. 6

- During interview, Examiner admitted Specification established criticality.
- Track 1 Application granted in March 2018 (less than 7 months after filing date)

U.S. Patent Aug. 25, 2015 Sheet 3 of 9 US 9,115,506 B2



## Other Secondary Considerations – Evidence Discovered After Filing

---

- **Commercial Success**
- **Long-Felt Need**
- **Failure of Others**
- **Skepticism of Experts**
- **Copying**
- **Inoperability of reference**
  
- **Commercial Success**
  - **SALES FIGURES MUST BE ADEQUATELY DEFINED**
    - **Market Share more important and gross sales**
  
  - **NEXUS: COMMERCIAL SUCCESS MUST BE COMMENSURATE IN SCOPE WITH CLAIMS**
    - **Customer declarations/surveys show claimed features drove sales**
    - **Can be attributed to FUNCTIONS AND ADVANTAGES DISCLOSED OR INHERENT IN THE SPECIFICATION DESCRIPTION**

# Commercial Success Example – RED Digital

- Claims: Digital Camera that compresses RAW image data, at least 2000 pixel H resolution, visually lossless
  - Prior Art: Digital Camera compresses RAW image data, 1920 H resolution, visually lossless.
  - Rejection During Reexamination: PAR + obvious to increase resolution
- Evidence
  - Declaration from CFO showing sales.
  - 3<sup>rd</sup> Party Article showing RED captured 47.9% of global market for Cinema Movie Cameras in first 6 years of sales.

Percent of Market Share by Revenue  
Cinematography Cameras Segment: Global, 2012

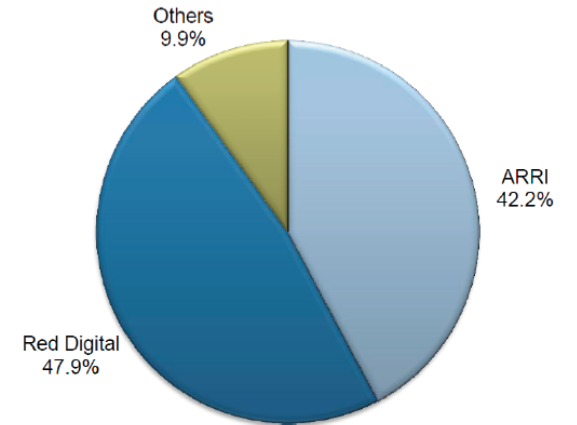

- Declarations from 3 Oscar Winning Film makes - Peter Jackson (Hobbit/Lord of the Rings) Purchased 50 cameras because of **claimed features, not price.**
- Examiner admitted, RED achieved commercial success.
- Reexamination resolved in 18 months.
- RED filed many lawsuits and obtained favorable settlements and licenses.

REDCOM.007X1 PATENT

IN THE UNITED STATES PATENT AND TRADEMARK OFFICE

Applicant	: James Jannard, et al.	CERTIFICATE OF EFS WEB TRANSMISSION
Reexam Control No.	: 90/012,550	I hereby certify that this correspondence, and any other attachment noted on the automated Acknowledgment Receipt, is being transmitted from within the Pacific Time zone to the Commissioner for Patents via the EFS Web server on:
Reexam Filed	: September 13, 2012	July 1, 2013
Patent No.	: 8,174,560	(Date)
For	: VIDEO CAMERA	/Michael Quilliana/
Examiner	: Henry N. Tran	Michael A. Quilliana, Reg. no. 42,611
Art Unit	: 3992	
Conf No.	: 1159	

**DECLARATION OF SIR PETER JACKSON UNDER 37 C.F.R. §1.132**

Commissioner for Patents  
P.O. Box 1450  
Alexandria, VA 22313-1450

Dear Sir:

I, Sir Peter Jackson, declare that:

1. I am a professional film maker and have served as Producer, Director, and Writer, in various capacities in my projects. My filmography is attached as Exhibit A. Exhibit B includes a list of awards and nominations I have received.
2. In my experience with various productions, I have personally used and directed the use of cameras made by Red.com, Inc., ("RED").
3. I believe I was the first person to direct a film that was shot using one of RED's cameras, back in 2007. That camera, a pre-production version of RED's RED ONE, had the ability to record, onboard, compressed raw image data, at 2K and higher resolutions, yet remain visually lossless. Specifically, the RED ONE camera could compress and record raw digital image data having a resolution of at least 2K (including 4K) into a storage device of the camera (e.g., carried on or within a portable housing of the camera) at a frame rate of at least about twenty-three

# Nexus

7. A bicycle chainring for engagement with a drive chain, comprising:

a plurality of teeth formed about a periphery of the chainring, the plurality of teeth including a first group of teeth and a second group of teeth, each of the first group of teeth wider than each of the second group of teeth and at least some of the second group of teeth arranged alternatingly and adjacently between the first group of teeth,

wherein each of the plurality of teeth includes a tooth tip;  
wherein a plane bisects the chainring into an outboard side and an inboard side opposite the outboard side; and

wherein at least the majority of the tooth tip of at least one of each of the first and second groups of teeth is offset from the plane in a direction toward the inboard side of the chainring.

More specifically, SRAM will bear the burden of proving that the evidence of secondary considerations is attributable to the claimed combination of wide and narrow teeth with inboard or outboard offset teeth, as opposed to, for example, prior art features in isolation or unclaimed features.

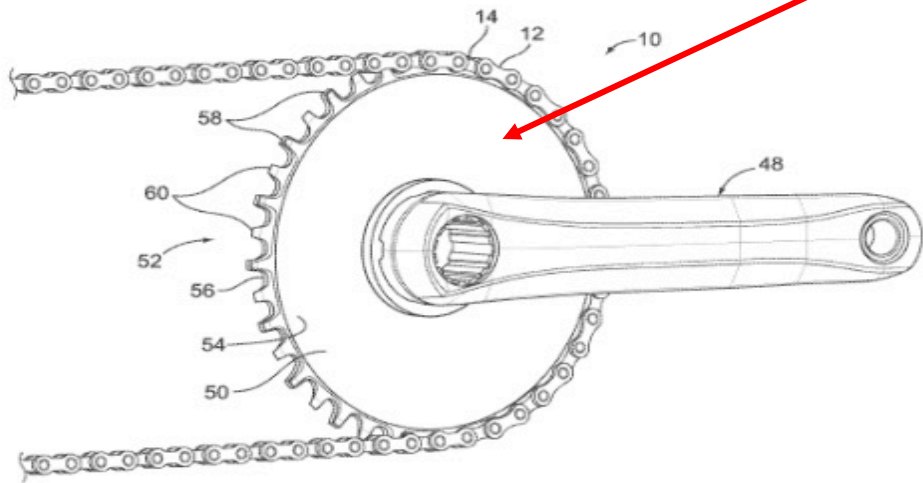
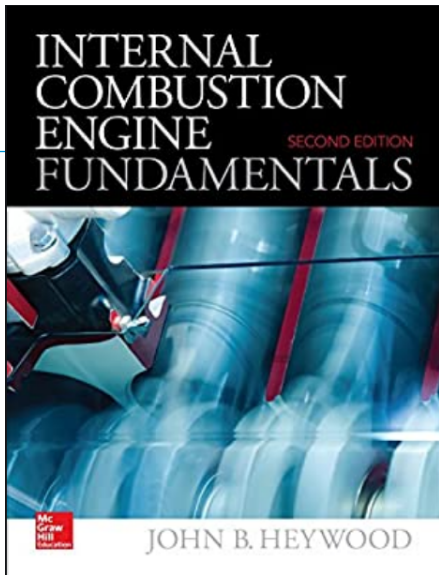

FIG. 3



# Long Felt Need and Skepticism of Experts § 716.05

- “Expressions of disbelief by experts constitute strong evidence of nonobviousness”
- “Invention met with initial incredulity and skepticism of experts was sufficient to rebut the *prima facie* case of obviousness.” ***Burlington Industries Inc. v. Quigg***, 822 F.2d 1581, 3 USPQ2d 1436 (Fed. Cir. 1987)
  - Example use of Skepticism of Experts
    - Claim: Fuel Injection System: 1<sup>st</sup> injection for combustion up to peak pressure, then 2<sup>nd</sup> fuel injection producing constant temperature combustion
    - Prior Art Ref 1: All combustions can have peak pressure then constant temperature portion
    - Prior Art Ref 2: Multiple Injections can be used to spread out peak pressure of combustion
    - Rejection in Reexamination: Obvious to use multiple injections of PAR1 to produce combustion up to peak pressure then constant temperature of PAR 2
      - Evidence: Technical Expert Report by John B Heywood from prior litigation against Caterpillar: invention is “impossible”.
      - Evidence: infringement by commercial embodiment.
      - USPTO – Allowed claims no amendment.
      - Patent Owner obtained settlements numerous engine manufacturers.



1  
2  
3  
4  
5  
6  
7  
8  
9  
10  
11  
12  
13  
14  
15  
16  
17  
18  
19  
20  
21  
22  
23  
24  
25  
26  
27  
28

UNITED STATES DISTRICT COURT  
CENTRAL DISTRICT OF CALIFORNIA  
WESTERN DIVISION

KRUSE TECHNOLOGY PARTNERSHIP,  
Plaintiff,  
vs.  
CATERPILLAR INC.,  
Defendant.

AND RELATED COUNTERCLAIM

Case No. CV04-10435 GPS (FMOx)  
**EXPERT REPORT OF JOHN B. HEYWOOD**  
Hon. George P. Schiavelli

WREY LLP  
DM\_US8261252.v1



# Inoperability of References § 716.07

- Affidavits or declarations attacking the operability of a patent cited as a reference must rebut the presumption of operability by a preponderance of the evidence. *In re Sasse*, 629 F.2d 675, 207 USPQ 107 (CCPA 1980)
- Where the affidavit or declaration presented asserts that the reference relied upon is inoperative, the claims represented by applicant must distinguish from the alleged inoperative reference disclosure. *In re Crosby*, 157 F.2d 198, 71 USPQ 73 (CCPA 1946)

## – Example: Kruse Reexamination

- Claim: Fuel Injection System: 1<sup>st</sup> injection for combustion up to peak pressure, then 2<sup>nd</sup> fuel injection producing constant temperature combustion
- Prior Art Ref: Multiple Fuel Injection produced simultaneous constant pressure and constant temperature.
- Rejection: Obvious to use multiple injections of PAR1 to produce combustion up to peak pressure then constant temperature of PAR 2
  - Evidence: Declaration by Scientist from Lawrence Livermore Laboratories with computer simulations of prior art device, inoperable
  - USPTO – Allowed claims no amendment

KTP.001X3

PATENT

### IN THE UNITED STATES PATENT AND TRADEMARK OFFICE

Applicant : Douglas C. Kruse  
Reexam Control No. : 90/011,632  
Reexam Filed : April 7, 2011  
Patent No. : 6,058,904  
For : INTERNAL COMBUSTION ENGINE WITH LIMITED TEMPERATURE CYCLE  
Examiner : David O. Reip  
Art Unit : 3993  
Conf No. : 5800

#### CERTIFICATE OF EFS WEB TRANSMISSION

I hereby certify that this correspondence, and any other attachment noted on the automated Acknowledgement Receipt, is being transmitted from within the Pacific Time zone to the Commissioner for Patents via the EFS Web server on:

November 23, 2011

(Date)

/Michael Guilliana/

Michael A. Guilliana, Reg. No. 42,611

#### DECLARATION OF DR. DANIEL FLOWERS UNDER 37 C.F.R. §1.131

Commissioner for Patents  
P.O. Box 1450  
Alexandria, VA 22313-1450

Dear Sir:

I, Daniel L. Flowers, declare that:

I have worked in the field of advanced energy technologies for more than 15 years, conducting experimental and analytical research in thermal sciences and combustion. Presently, I am employed as the Associate Program Leader for Combustion and Alternative Fuels at Lawrence Livermore National Laboratory. I have been working in the area of Homogeneous Charge Compression Ignition (HCCI) engine combustion since joining LLNL in 1998. I lead several combustion research projects at LLNL in the areas of HCCI, hydrogen and Diesel combustion. Recently, during leave from LLNL, I led research and development at Cleveves Engines, an energy research startup company. I also served as Associate Technical Editor of the ASME Journal of Energy Resource Technologies in 2007 and 2008. I hold Ph.D. (2001), M.S. (1997), and B.S. (1996) degrees in Mechanical Engineering from the University of California,

# General Prosecution Tips - Addressing Section 103 Rejections/Rationale

---

- Persuasive / Compelling Story can overcome strong obviousness rejections
- Evidence of Criticality / Unexpected results – Better to be in Original Specification
  - If not, can be submitted by Declaration in OA response
- 8 Flavors of “Legal Rationale” of Obviousness have many nuances.
  - Each Flavor has unique requirements
  - Understanding each flavor can inform claim strategies for drafting Original Application
- Track 1 Expedited Examination is more successful.
- Critical to tie Claims to Evidence (“Nexus”)
  - E.g., Commercial Success

# Knobbe Martens

Dan Altman

[dan.altman@knobbe.com](mailto:dan.altman@knobbe.com)

949-721-2875

Michael Guiliana

[michael.guiliana@knobbbe.com](mailto:michael.guiliana@knobbbe.com)

949-721-6384

Hiro Kubota

[hiro.kubota@knobbe.com](mailto:hiro.kubota@knobbe.com)

949-721-6363

Mauricio A. Uribe

[mauricio.uribe@knobbe.com](mailto:mauricio.uribe@knobbe.com)

206-405-2004